



English

Original Instructions

Installation, Operation and Maintenance Instructions

Subrotor

Spares & Service Contact Details

Mono UK

Spares	+44 (0)161 214 2380 (direct line 8.15 am – 5.00 pm)
E-mail	spares@mono-pumps.com
Service	+44 (0)161 214 2390 (direct line 8.15 am – 5.00 pm)
E-mail	customerservices@mono-pumps.com
Service	+44 (0)161 339 9000 (24 hrs)

Mono Australia

	Telephone	Facsimile
Melbourne	(03) 9580 5211	(03) 9580 9036
Sydney	(02) 9521 5611	(02) 9542 3649
Brisbane	(07) 3350 4582	(07) 3350 3750
Adelaide	(08) 8447 8333	(08) 8447 8373
Perth	(08) 9479 0444	(08) 9479 0400
Darwin	(08) 8984 3099	(08) 8947 0540
Tasmania	0417 345 814	(03) 6330 2051
E-mail	ozsales@mono-pumps.com	

Mono New Zealand

Spares & Service	+64 (0)9 829 0333
E-mail	info@mono-pumps.co.nz

Monoflo USA

Spares & Service	+1 713 466 7999
E-mail	inquire@monoflo.com

Monoflo South America

Spares & Service	+54 4296 8997	+54 4284 0323
E-mail	inquire@monoflo.com	

Mono China

	Telephone	Facsimile
Beijing	+86 (0) 10 6461 1115	+86 (0) 10 8486 8481
Shanghai	+86 (0) 21 5915 7168	+86 (0) 21 5915 6863
E-mail	monoshanghai@nov.com	

Contents

Warranty	
Warranty Statement	3
Declaration	
Manufacturer's Declaration	4
Declaration of Conformity	4
Introduction	
Intended Use	5
System Overview	5
Requirements for Installation	5
Specifications	
Motor Specifications	6
Motor Cable Specifications	7
Single Phase Controller Specifications	8
Pump Specifications	9
Installation	
Pre-Installation Checks	10
Generator Recommendations	11
Splicing the Motor Cable	12
Splicing and Insulating Connection:	12
Electrical Connection	13
Installation of the Subrotor Controller	13
Recommended Installation of a Single Phase Subrotor System	14
Three Phase Motors	15
Submersible Motor Cooling	15
Lightning	16
Pressure Systems	16
Installing the Pump	16-18
Operations	
Operating the Subrotor Controller	19
Dip Switches	20
Subrotor Controller Indicator Lights and Their Meaning	21
Examples of Use	22
Maintenance	
Subrotor Pump Wet End - Disassembly	23
Subrotor Pump Wet End - Assembly	24-25
Spare Parts	26
Fault Finding	
Fault Finding	27-28

Warranty

1. The Subrotor Pump manufactured by Mono Pumps is covered by warranty for a period not exceeding twelve months from purchase.
2. Mono Pumps will make good by repair, or at their option, the replacement of faulty parts under warranty, providing always that:
 - (a) The equipment was correctly installed and properly used in accordance with Mono Pumps Installation, Operation and Maintenance Instruction and accepted codes of good engineering practice.
 - (b) The claim for goods under warranty arises solely from faulty design, material or workmanship.
 - (c) The repair is carried out in the Mono factory or by an authorised agent or distributor appointed by Mono Pumps.
 - (d) All freight costs to and from the factory or repair agent are to be paid by the purchaser.
3. In the case of equipment or components which are not of Mono manufacture, but supplied by them, the warranty is limited to that extended by the suppliers or manufacturers of such equipment.
4. Mono Pumps warranty does not cover any of the following:
 - (a) Claims for third party liability of damage caused by failure of any of the company's products.
 - (b) Damage caused by abnormal operating conditions, war, violence, storm cataclysm or any other force.
 - (c) Damage caused by the equipment being used for an application for which it is not recommended.
 - (d) Damage caused by sand or abrasive materials, corrosion due to salt water or electrolytic action.
 - (e) Damage to the motor if the motor is found to have been disassembled before being returned to Mono Pumps.
 - (f) Damage caused by running the pump dry.
5. The decision of Mono Pumps in relation to any claims or disputes over warranty is final.
6. The warranty is in lieu of all other warranties and conditions expressed or implied, written or oral, statutory or otherwise, which are hereby negated and excluded.
7. This express warranty does not exclude any conditions or warranty implied by the Trade Practices Act 1974 or separate State laws and in addition to any other right, that the original purchasers or any subsequent purchaser may have at law.

In case of claim please contact your Authorised Mono Dealer or contact Mono Pumps (Australia) Pty. Ltd.

EC Declaration as defined by Machinery Directive 2006/42/EC.

The following harmonised standards are applicable: BS EN 809, BS EN ISO 12100 Parts 1 & 2

EC Declaration of Incorporation

This declaration is only valid when partly completed machinery has been supplied.

In this case, the machinery meets the requirements of the said directive and is intended for incorporation into other machinery or for assembly with other machinery in order to constitute relevant machinery as defined by the said directive including any amendments, which are valid at the time of supply.

IMPORTANT

This machinery must not be put into service until the relevant machinery into which it is to be incorporated has been declared in conformity to the said directive.

This declaration is only valid when the machinery has been installed, operated and maintained in accordance with these instructions and safety guidelines contained within as well as instructions supplied for equipment assembled with or intended for use with this equipment.

EC Declaration of Conformity

This declaration is not valid for partly completed machinery has been supplied.

In this case the machinery meets the requirements of the said directive including any amendments which are valid at the time of supply.

We further declare that, where applicable, said machinery also meets the requirements of:

The EMC Directive 2004/108/EC
The Low Voltage Directive 2006 /95/E
The Pressure Equipment Directive 97/23/EC
The Outdoor Noise Directive 2005/88/EC
The Drinking Water Directive 99/83/EC

IMPORTANT

This declaration is only valid when the machinery has been installed, operated and maintained in accordance with these instructions and safety guidelines contained within as well as instructions supplied for equipment assembled with or intended for use with this equipment.



**Mr C. Q. Griffiths - Engineering Services Manager.
for Mono Pumps Limited, Martin Street, Audenshaw,
Manchester England, M34 5JA**

Introduction

Intended Use

The Subrotor system is designed for pumping potable water from boreholes using either 240 volt or 415 volt power. Do not use the system for any other purpose.

System Overview

This manual will provide the user with essential information on the installation, operation and maintenance of the Mono Subrotor System.

The pumping of sand or other abrasives may damage the pump and should be avoided. Bores should be screened and properly developed before installing your Mono Subrotor pump.

If excessive sand is present in the bore, then a Mono borehole pump with column and shafting is recommended for trouble free service.

Typical Subrotor Pump Installation

It is recommended that the pump be mounted vertically. If the pump installation is horizontal, the pump must be supported by 50x50 angle over the full length of the pump (including motor).

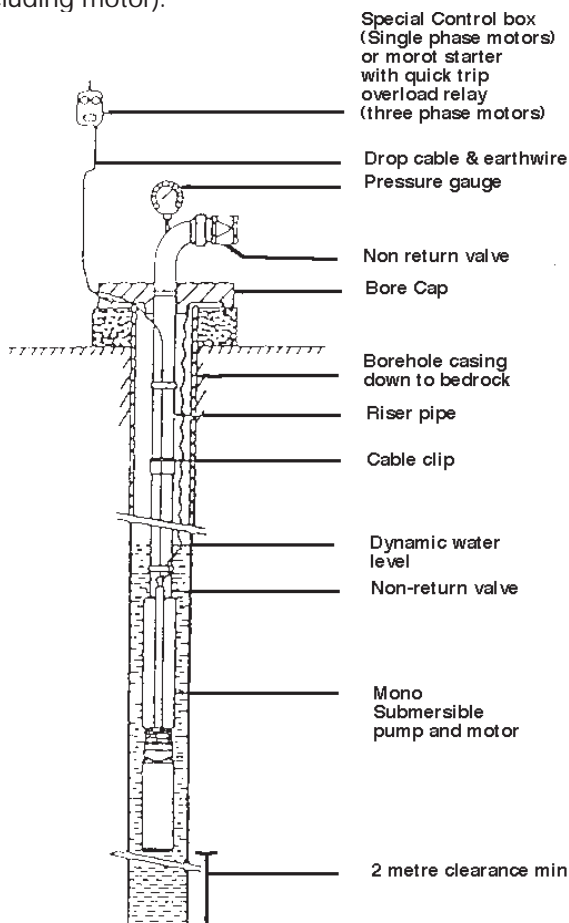

Requirements for Installation

- (1) A Mono Subrotor pump and electro sub motor suited to the electrical supply and borehole conditions.
- (2) Electrical protection controls for the motor:
 - (a) FOR SINGLE PHASE MOTORS
 - i. A control box matched to the electrical supply voltage and the motor power.
 - ii. The line and control box must be protected (fuse/breaker).
 - (b) FOR THREE PHASE MOTORS

An approved contactor and motor protection relay (magnetic starter), with overloads and approved surge arrestors which must be earthed to the motor.
 - (c) An isolator or circuit breaker for both single and three phase motors in accordance with local electrical regulations.
- (3) Sufficient length of underwater cable correctly sized to the pump motor.
- (4) Suitable earth cable.
- (5) Riser pipe in steel, PVC or polyethylene.
- (6) Bore cap.
- (7) If required: Pressure gauge, pipe bends, non-return valve, union or flange, cable clips and underwater jointing kit (termination kit).



Subrotor pump should never be throttled using a gate valve.

- 8) Stainless steel safety rope (to be fitted when delivery pipe is installed).



All electrical connections must be performed by a qualified electrician.

Specifications

Motor Specifications

Part Number	Power (kW)	voltage (V)	Run Current (Amps)	Locked Rotor Current (Amps)	phases	RPM
ESM-103	0.75	415	2.2	8.5	3	2800
ESM-153	1.1	415	3.2	16	3	2800
ESM-203	1.5	415	3.95	19.7	3	2800
ESM-303	2.2	415	5.3	26.5	3	2800
ESM-101	0.75	240	6.1	22	1	2820
ESM-151	1.1	240	7.9	28	1	2820
ESM-201	1.5	240	10	34	1	2820
ESM-301	2.2	240	15	52.5	1	2820

Mechanical Specifications

Part Number	Motor Casing Length	Outside Diameter	Weight	Minimum Bore Diameter
ESM-103	340mm	94mm	7.7 kg	100mm (4")
ESM-153	370mm	94mm	9 kg	100mm (4")
ESM-203	400mm	94mm	10.5 kg	100mm (4")
ESM-303	480mm	94mm	13.5 kg	100mm (4")
ESM-101	370mm	94mm	9 kg	100mm (4")
ESM-151	400mm	94mm	10.5 kg	100mm (4")
ESM-201	440mm	94mm	12 kg	100mm (4")
ESM-301	480mm	94mm	12.5 kg	100mm (4")

Resistance Between Phases

Pump Size	Resistance between Phases (Ohms)		
	Black/ Blue	Blue/ Brown	Black/ Brown
0.75kw/ 1.0 hp 415 volts	19.8	19.8	20.1
0.75kw/ 1.0 hp 240 volts	3.7	13.3	9.6
1.1kw/ 1.5 hp 415 volts	12.5	12.6	12.5
1.1kw/ 1.5 hp 240 volts	3.1	7.4	4.7
1.5kw/ 2.0 hp 415 volts	10.8	10.7	10.6
1.5kw/ 2.0 hp 240 volts	3.2	6.8	4.5
2.2kw/ 3.0 hp 415 volts	7.2	7.0	7.1
2.2kw/ 3.0 hp 240 volts	2.2	5.0	3.6

Specifications

Motor Cable Specifications

Single Phase 240v 50Hz

Three Phase 415v 50Hz

Motor (kw)	Current (Amps)	1.5mm	2.5mm	4.0mm	6.0mm	10.00mm	Current (Amps)	1.5mm	2.5mm	4.0mm
0.75	6.1	50m	84m	134m	201m	N.A.	2	308m	N.A.	N.A.
1.1	8.0	38m	64m	102m	154m	256m	2.9	212m	354m	N.A.
1.5	10.0	30m	51m	82m	123m	184m	3.8	162m	270m	432m
2.2	14.9	N.A.	34m	55m	82m	137m	5.3	116m	193m	309m

Notes:

1. The lengths shown are the maximum permissible run in metres from the motor to the control box.
2. The calculations are based on using Mono supplied cables stranded with 0.20mm copper conductors.

Specifications

Single Phase Controller Specifications

Electrical

Voltage	240V +/-6%		
Frequency	50Hz		
Model No.	Power (Hp)	Power (kW)	Current (Amps)
SUB CTRL0750	1.0	0.7	6.1
SUB CTRL1100	1.5	1.1	8.0
SUB CTRL1500	2.0	1.5	10.0
SUB CTRL2200	3.0	2.2	14.9

Environmental

Storage Temperature	-10 to 60oC
Operating Temperature	-10 to 50oC
IP Rating	IP66
Humidity	95% Max.

Dimensions & Weight

Dimensions (in carton)	270 x 390 x 310mm
Weight (in carton)	2.7kg

Dimensions

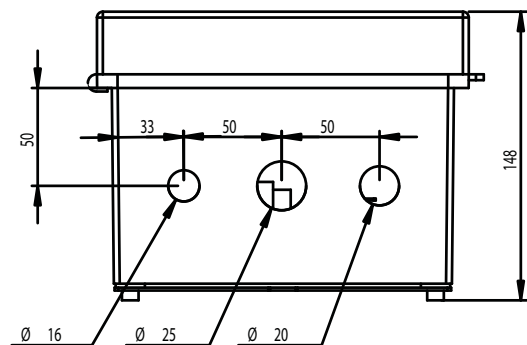
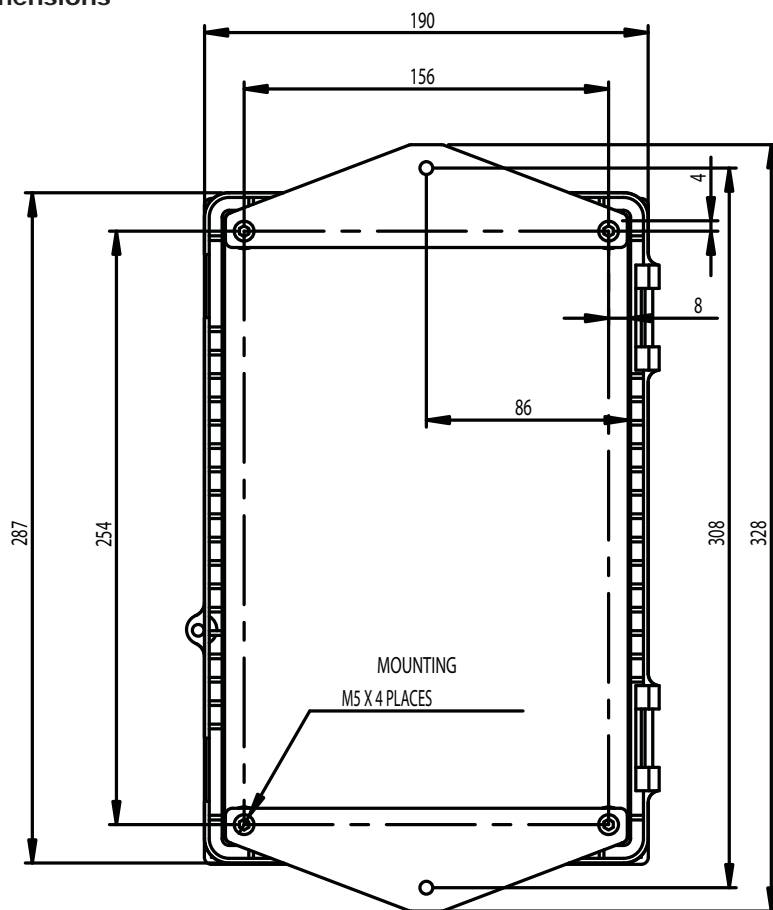

Specifications

Pump Specifications

Model Numbers	SM022	SM041	SM042	SM061	SM062	SM101	SM102	SM151
Power [kW]	0.75	0.75	1.5	1.1	2.2	1.5	2.2	2.3
Maximum Speed [RPM]	2800	2800	2800	2800	2800	2800	2800	2800
Flow at Maximum Speed [lpm]	14.4	28.2	31.8	48.6	45.6	78.0	85.2	90.6
Maximum Discharge Pressure [kPa]*	1500	750	1500	750	1500	750	1200	750
Length of Pump (without motor) [mm]	860	850	940	850	940	890	1010	900

* Discharge pressures are maximum for the pump only. Pressure limitations due to motor current will result in lower maximum pressures for some system.

Mechanical Specifications

Typical Weight Without Motor	7.9 kg
Outlet	1½ inch BSP threaded
Maximum Starts Per Hour	6
Max. Depth of Immersion (water level above pump)	150m
Min. Depth of Immersion (water level above pump)	2m

Mounting arrangement

To NEMA standard 17/5/72 motors

"Submersible Motors for Deep Well Pumps 4 inch"

The pump can be mounted on a NEMA shaft if an adaptor is used.

Materials (All models)

Motor Adaptor	316 cast stainless steel
Pump Barrel	304 stainless steel
Socket Adaptor	304 stainless steel
Stator	304 stainless steel tube with natural rubber lining
Flexishaft	431 stainless steel coated with Halar
Rotor	316 stainless steel with Hard Chrome Plating
Non Return Valve	Bronze with nitrile seat and anti-rotating pin
O Rings	Nitrile

Water Quality

Maximum Water Temperature	35 deg C
pH Range	6.0 to 8.5
Hardness Range	2000 mg/L
Salt Concentration	500 ppm

Installation

Pre-Installation Checks

1. Unpack the unit carefully to avoid damage to motor, pump and motor cable.
2. Compare motor, pump and control equipment to ensure that they are matched.
3. Check the power source with a voltmeter and compare with the motor and controller or starter.
4. If a three phase motor, check that the contactor and motor protection relay is approved, and check the overloads to ensure that they are sized for the full load motor current.
5. If a single phase motor, check that the circuit breaker is rated at the full load motor current and is available as back-up protection.
6. If a three phase motor, check that surge arrestors (Heineman surge arrestors models LAS 1, LAS 2, or LAS 3 are also approved) are available for each phase.
7. Check the direction of rotation with three phase motors before installation, as pump components may unscrew when operated in the wrong rotation.

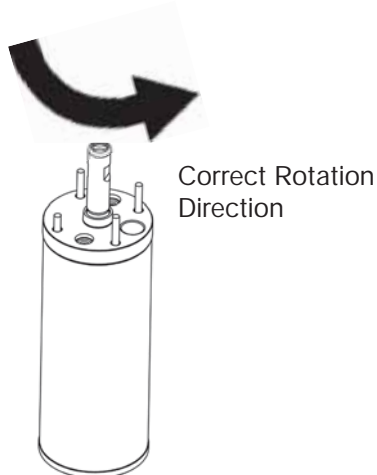

1. In all cases an adequately sized earth cable must be connected to the arrester/earth terminal in the controller/starter and the upper cable guard screw on the pump.
2. Check underwater cable size to ensure adequate voltage at the motor. Refer to table in Motor Cable Specification for cable size and maximum length.



CAUTION: Be sure to maintain the colour sequence at the cable joint, particularly with single phase motors.

9. Determine the borehole depth and standing water level.



CAUTION: Ideally, the motor should be set just above the level at which water enters the borehole. If this level is uncertain or cannot be established, then a "flow inducer" tube must be fitted over the motor and pump inlet to ensure adequate cooling.

General

The warranty does not cover damage due to running the pump dry. If there is a possibility that the pump will pump more water than the borehole can supply, Mono Pumps recommend that a water level controller is fitted to the system (available from Mono).

The warranty does not cover damage to the motor or pump caused by water quality outside the limits specified in the Pump Specification section of this manual.

Installation

Generator Recommendations

Minimum Sizes For Single Phase Subrotor Systems

Motor Size (kW)	Run Current (A)	Run (kVA)	Start Current (A)	Start (kVA)
			Min	Min
0.75	6.1	1.5	15.5	3.7
1.1	8.0	2.0	20.5	4.9
1.5	10.0	2.4	25.0	6.0
2.2	14.9	3.6	37.5	9.0

Notes:

1. Generator must supply the run kVA continuously (even for small loads).
2. The surge start current/kVA that a generator can supply, must meet the minimum requirements above. Start kVA is required for <1 second. Given the above specifications, a generator supplier should be able to make a decision on the appropriate generator for this application.
3. If the generator is too small to start the motor, then:
 - a) Motor will not start or starting will be poor.
 - b) Generator will stop or stall.
 - c) The breaker of the generator will trip.
4. The actual VA required and motor size (kW) are significantly different. There are two reasons for this:
 - a) As the motor rating is at the shaft, the motor is not 100% efficiency. More power on the input is required.
 - b) The motor power factor is not 1, therefore its VA requirements are different from its power requirements. $\text{Power} = \text{power factor} \times V \times I$. Power factor can vary between 0.5 and 0.94 depending on the load, i.e. higher the load higher the power factor.

Installation

Splicing The Motor Cable

The connection between the motor cable and the motor leads must be perfectly watertight. We recommend using the MONO SUBMERSIBLE - JOINING KIT: PART NO. ESA301111.

Contents	Quantity
Crimp Connector - Small	4
Crimp Connector - Large	4
Heat Shrink Tube - Small	4
Heat Shrink Tube - Large	1

- Kit is for use when connecting 4" submersible motors, to motor cable up to size 10mm.
- Small sized crimp connectors should be used when connecting all sized cables 4 and 6mm².

Preparation:

1. Outer insulation to be cleaned with an alcohol impregnated cloth.
2. The three motor leads together with the earth to which the drop cable will be connected must be cut off in a staggered manner as illustrated.
3. The motor cable must be prepared in a like manner making sure that wires to be connected, are properly matched for length to the correct motor lead.
4. Match motor lead colours to motor cable colours as follows:

Motor Leads		Motor Cable Lead
Blue	to	Blue
Black	to	White
Brown	to	Red
Green/Yellow	to	Green/Yellow

Note: Always be certain to match green/yellow earth leads of motor and motor cable.

5. Next, slide the large diameter heat shrink tubing back over the motor cable clear of the joint and the four smaller tubes over the motor leads, clear of the joint.

Splicing and Insulating Connection:

1. Trim the insulation back 8mm on each lead.
2. Join leads using correct size crimp connectors and a suitable crimping tool. (Alternatively joints may be twisted and soldered).
3. Slide each of the smaller heat shrink tubes in turn back over each connection.
4. Using a heat source such as a gas torch, candle, heat gun, etc., carefully heat tubing, starting from centre of splice and working towards end while rotating wire.
5. Shrinkage is complete when sealant runs from joint at each end.
6. When cool, each joint should be sealed.
7. Slide larger diameter shrink tube back over splices and heat in a similar manner as for small shrink tube.
8. The seal is now fully water tight and ready for installation.

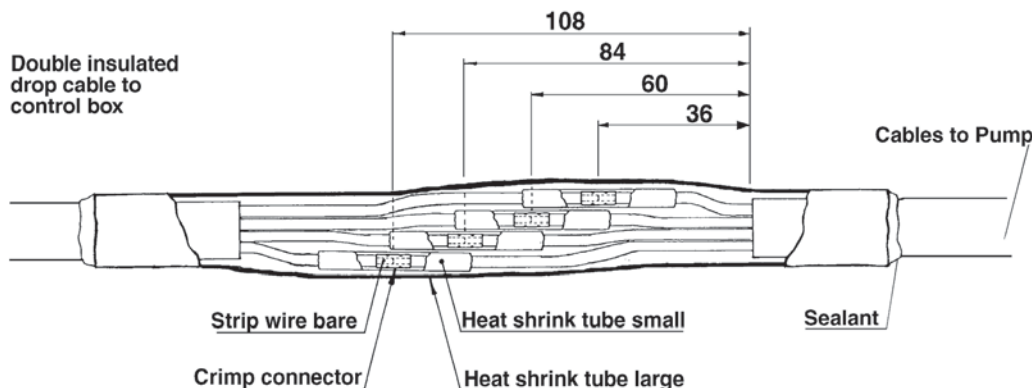

Installation

Electrical Connection



Electrical connections should be carried out by an authorised electrician in accordance with local regulations, and the diagrams for the motor protection starter and control components used.



CAUTION: Be sure to ground the unit before making any other electrical connections.

Preliminary Motor Tests

Perform before and after installation into a well.



Motor and motor cable should not be connected to the controller or mains supply. Disconnect before conducting tests to avoid electric shock.

Insulation Test:

1. Immerse motor, junction and motor cable into a body of water.
2. Use a 500V MEGGER to test the insulation between each power lead and earth (green/yellow). The resistance value should not read less than 10M Ω .
3. After installation or during operation the unit should have an insulation reading between 1 to 2M Ω .

Conductivity Test:

Use an ohmmeter to check the motor and cable connections between phases.

Consult table under Motor Specifications for expected value. Variation greater than 20%, indicates a problem.

Control Boxes

The single phase control box supplied by Mono is intended for the operation of the Mono Subrotor pump only.

Single phase submersible motors require the use of above ground control boxes for starting and thermal protection. Operation of motors without control boxes or with incorrect boxes can result in failure of motors and voids warranty.

Installation of the Subrotor Controller

Ensure all electrical connections are made in accordance with local regulations.

Ensure that all cabling is installed so that the cable is protected from damage.

Ensure that the installation of the cable does not represent a trip hazard.

Wiring Diagram

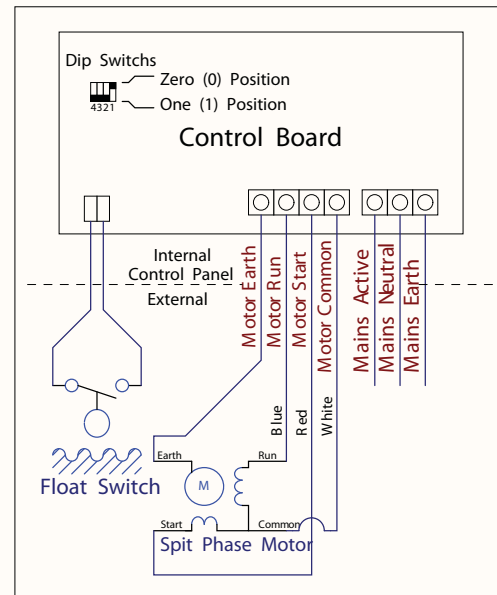

Dip switches as per the wiring diagram are as factory settings.

Dip switches will need to be changed to the desired mode. See Dip Switches under Operations for instruction.

The Subrotor controller can be exposed to the environment as long as:

- The cable entry is properly sealed using the supplied cable grommets.
- The controller is mounted vertically to a secure fixture i.e. post.

Installation

Recommended Installation of a Single Phase System

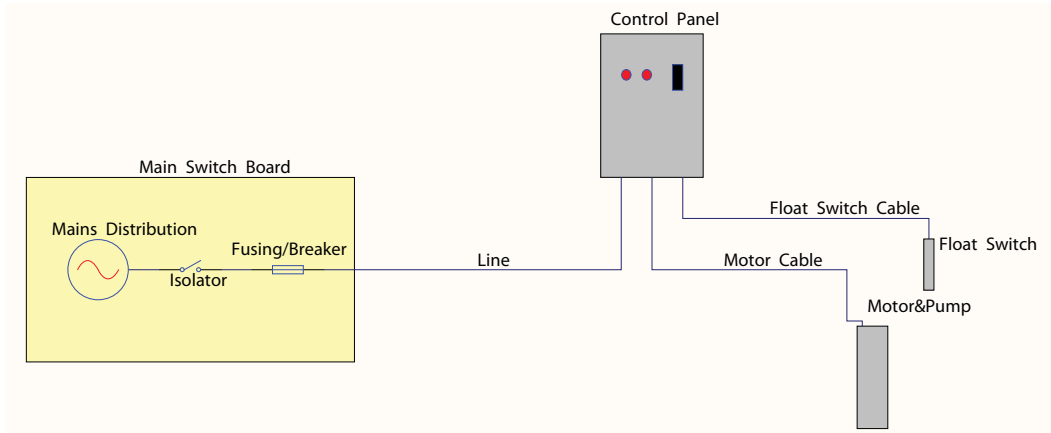

Component	Recommendations
Mains Distribution	240V +/-6%, 50 Hz
Isolator	<ol style="list-style-type: none"> 1. Isolator is required so that the Subrotor System can be isolated from the mains power. This allows any work that needs to be conducted on the Subrotor System to be done safely. 2. It is recommended that the isolator has a lockout facility.
Fusing/Breaker	<ol style="list-style-type: none"> 1. Installation of a fusing/breaker is required to protect the controller and line. 2. Fusing/breaker must be adequately rated so that is capable of protecting the Subrotor system from a line fault. 3. The fusing/breaker rating must also be adequately rated so that it is able to handle the expected load current from the motor (this information can be found on the name plate of the motor and controller).
Line	It is important to consider the line voltage drop from the main switch board to the controller. The drop in this line can more significant that than the drop from the controller to motor.
Controller	<ol style="list-style-type: none"> 1. The Mono Subrotor controller is fitted with a magnetic-hydraulic breaker that ensures the protection of the motor and pump. It is important to make sure the model of the controller matches the motor size before installing. 2. The Subrotor controller is capable of been exposed to the environment as long as: <ul style="list-style-type: none"> • The cable entry is properly sealed using the supplied cable grommets. • The controller is mounted vertically to a secure fixture i.e. post.
Float Switch Cable	This must be a submersible cable.
Float Switch	<ol style="list-style-type: none"> 1. The float switch is in the closed position when the pump operates and in the open position when the pump stops. 2. The float switch control feature can also be used with other equipment that provides a voltage free contact,
Motor Cable	<ol style="list-style-type: none"> 1. This must be submersible cable. 2. Consult Motor Cable Specification for line voltage drop and recommended cable sizes.
Motor & Pump	<ol style="list-style-type: none"> 1. The voltage seen at the pump motor is effected by: <ul style="list-style-type: none"> • The voltage drop between the main switch board to the controller plus, • The voltage drop between the controller to the pump motor. 2. If the voltage is less than 240V -6%, then the pump and motor can be damaged. This is not covered by warranty.

Installation

Three Phase Motors

Motor Protection

Three phase submersible motors must be connected to an effective quick-tripping motor starter which must protect the motor and the cable against damage from voltage drop, phase failure, overload and locked rotor.

We recommend using a thermally compensated, quick trip thermal overload protector.

The thermal protector should be set to the motor rated current (motor name plate) or to the maximum operating current where operation is subject to changes. Operation at current values slightly higher than the rated current (x max. 1.1), can be tolerated provided the cause is only due to occasional changes occurring in the line voltage.

Manually operated motor starters should always be preferred. Mono sub rotor pumps should not be used where voltage varies by more than 6%. For automatic start/stop by a remote control etc., a separate contactor should be used in conjunction with the manually operated motor starter.

Start Up



Check the direction of rotation with three phase motors before installation is recommended, as pump components may unscrew when operated in the wrong rotation.

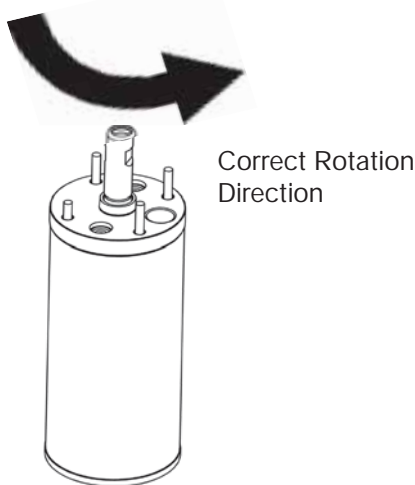

To reverse the direction of rotation with the three phase motors, interchange two leads on the terminal strip or the contactor.

Submersible Motor Cooling

The submersible motors are designed to operate with a minimum water velocity past the motor of 0.08m/sec. Under these conditions the maximum water temperature for the motor is 30°C. The following chart shows the required pump flow rate needed to achieve 0.08m/sec past the motor. A flow inducer tube should be fitted if the water enters the bore above the pump or if the flow rate is below the required flow in the following chart.

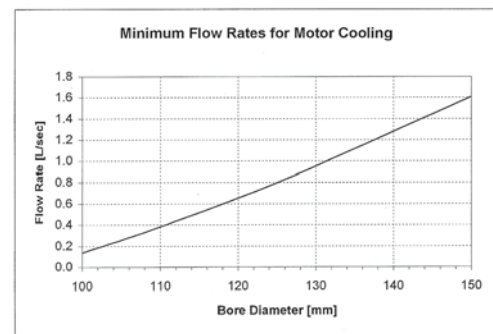

Notes:

- A flow inducer sleeve should always be fitted when the pump is installed in a large body of water. Make sure that such installation is properly earthed.
- A flow inducer sleeve is a tube over the motor, closed off above the pump intake and extended to the bottom of the motor or lower. The sleeve material is corrosion resistant metal or heavy plastic.
- If the casing is too small for a flow sleeve and you can't raise the pump, follow these steps:
 - (a) Tap a 6 mm tube (ID) into the pump outlet.
 - (b) Clamp it below pump and motor.
 - (c) Aim tube upwards so flow is introduced 0.3 metre below motor.
 - (d) Protect the tube with spacers and angle iron.

Installation

Lightning

In addition to the motor starter and overload unit, the installation may be fitted with a special over-voltage protection device which protects the motor against voltage surges which may be caused by lightning.

However, the over-voltage protection device does not protect against a direct stroke of lightning, but it does afford protection against voltage surges caused in the power lines when lightning strikes somewhere in the area.

The over-voltage protection device should be connected on the supply side of the motor starter.

Pressure Systems

If the system is set up with a pressure switch use the below arrangement.

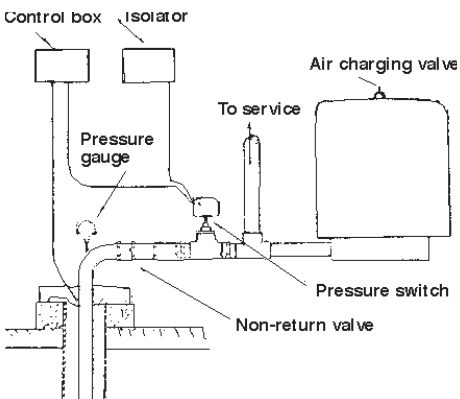

Installing the Pump

1. Prepare the Bore Cap
Assemble the bore cap as shown below

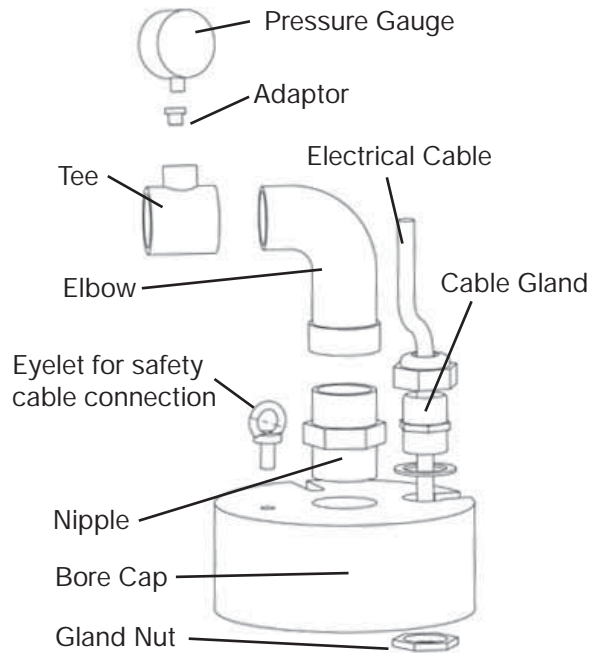

2. Determine the Pump Setting Depth
It is important to set the pump at the correct level in the borehole. Make sure that the unit is at least one metre above any gravel layer and one metre below the maximum draw down level.
3. Prepare the Pump
If the bore hole is less than 6" in diameter it will be necessary to trim the rubber stabilisers on the pump as shown below.

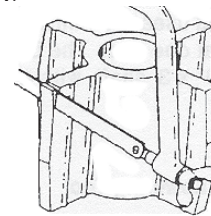

The pump can be installed on various rising main materials including polyethylene pipe. If using a polyethylene rising main Mono recommend that Class 12 pipe be used with cone type compression couplings.

Installation

Screw the fitting that connects the pump to the rising main into the threaded outlet on the top of the pump.

Lay the rising main out along the ground. Cut the rising main to the correct length and connect to the pump and borecap. The motor cable should be taped to the rising main every 3 metres with electrical tape. Leave 100 mm of slack in the electrical cable between each taping to allow for stretch of the rising main.



If the stretch of the rising main is not allowed for, the electrical cable will be pulled tight when the pump is installed resulting in failure of the cable splice or cable gland on the motor.

4. Water Level Probes

A low level probe should be installed on subrotor systems to prevent the pump from being run dry. However for both single and three phase subrotor systems, a delay needs to occur between when the low level probe closes and the pump starts. This is to prevent damage to the system that is caused by excessive cycling. This delay should be controlled by installing either a high level sensor or timer.

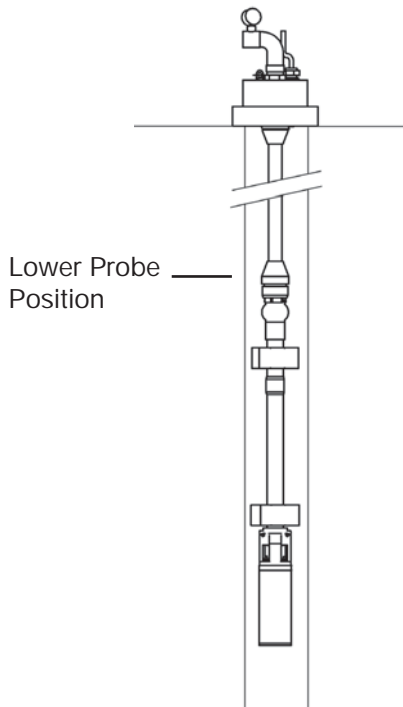

If a low level probe is been installed, the low level probe should be taped to the rising main with the power cable. The low level probe should be positioned above the pump as shown above.

If a high level probe is been installed then this probe is best left untapped so that it can be raised and lowered in the bore as required. As an initial setting, the high level probe should be positioned about 1 metre above the low level probe.

Using a Timer:

- For single phase systems, the subrotor controller has a built in timer. See Dip Switches in the Operation section to set the timer.
- For three phase systems, the timer should be set so that the pump starts after the bore has filled.

5. Attaching the Pump Safety Cable

The pump must be supported by means of a stainless steel safety cable. Assemble the clamps onto each end of the stainless steel safety cable.

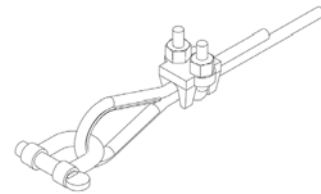

Connect the stainless steel safety cable to the pump as shown below. *Note: Motor is not shown for clarity.*

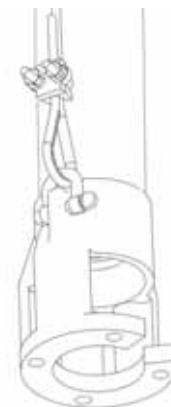

Installation

The other end of the safety cable will be connected to the bore cap when the pump has been installed.

6. Lubricating the Rotor and Stator

Before installing the pump, the rotor and rubber stator of the pump needs to be lubricated with a little water. Disconnect the pump from the motor by removing the four nuts and pulling the main body of the pump away from the motor. The rotor and drive shaft will remain attached to the motor. Wet the rotor and stator with clean water.



Do not use any lubricants on the rubber stator as these may interfere with/or damage the stator's rubber material.

Reassemble the pump body to the motor and tighten the four nuts.

7. Installing the pump into the borehole



Do not lower or ever support the pump by the submersible electrical cable.

As the pump is lowered down the bore, the weight should be taken through the safety cable or rising main.

When the pump has reached its required depth the bore cap should be positioned on the top of the bore. Slacken the safety cable slightly to ensure that the pump is hanging vertically. The safety cable can be secured to the bore cap at the completion of the installation.

8. Electrical Cable.

The electrical cable should be passed through a cable gland where it passes through the borecap to prevent chafing of the insulation. The electrical cable should be buried underground in electrical conduit between the borecap and the controller to protect it from damage (as per local electrical standards).

9. Non-Return Valve on the Delivery Pipe

If the system is fitted to a pressure tank or the static head is greater than 20 metres, then it is recommended that a non-return valve be installed. The non-return valve should be installed as close as possible to the outlet at the bore head, even though the pump is already fitted with one. The use of a non-return valve will ensure that the pump does not turbine backwards if the non-return valve on the pump was to leak.

Operation

Operating the Subrotor Controller



Opening the controller should be carried out by an authorised electrician in accordance with local regulations.



Controller should be isolated from mains power before any work is conducted on controller.

Set Up

Once wired in and the system has been tested in the factory setting mode, set the dip switches to the desired setting. If unsure what setting to use then set to any of the standard modes (switch 1 set to position one).

The majority of the time the unit will delay before switching on. The setting with the minimum delay is Float Mode - Delay 2 mins. The 2 min delay is only for testing so do not leave the unit with this delay for operation. The delays help protect the motor from excessive starting (particularly if automatically operated).

If the float switch is not being used ensure that the float switch inputs are linked together.

Operation

The pump will operate once the power switch is on.



Operation

Dip Switches

Switch				Setting
4	3	2	1	
↑	↑	↑	↑	Float Mode - Delay 10 min, Timer 10 min
↑	↑	↓	↑	Float Mode - Delay 20 min, Timer 20 min
↑	↓	↑	↑	Float Mode - Delay 40 min, Timer 40 min
↑	↓	↓	↑	Float Mode - Delay 60 min, Timer 60 min
↓	↑	↑	↑	Float Mode - Delay 90 min, Timer 90 min
↓	↑	↓	↑	Float Mode - Delay 120 min, Timer 120 min
↓	↓	↑	↑	Float Mode - Delay 150 min, Timer 150 min
↓	↓	↓	↑	Float Mode - Delay 2 min (factory setting, do not leave in this mode)
↑	↑	↑	↓	Standard Mode, Timer 10 min
↑	↑	↓	↓	Standard Mode, Timer 20 min
↑	↓	↑	↓	Standard Mode, Timer 40 min
↑	↓	↓	↓	Standard Mode, Timer 60 min
↓	↑	↑	↓	Standard Mode, Timer 90 min
↓	↑	↓	↓	Standard Mode, Timer 120 min
↓	↓	↑	↓	Standard Mode, Timer 150 min
↓	↓	↓	↓	Standard Mode, Timer 2 min

To access the dip switches, undo the two screws on the front panel as per page 19.

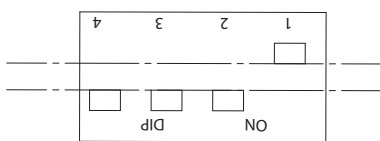
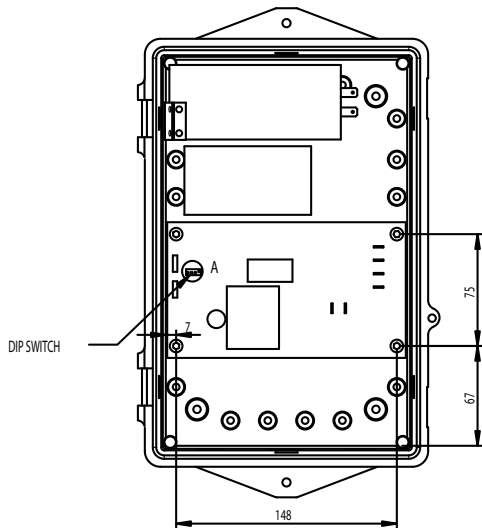

Detail A

Float Mode: In this mode, once the float switch is in the closed position, the selected delay time is activated. At the end of the delay time, if the float switch is still in the closed position the controller will activate the pump.











1. Float switch - Closed position.
2. Delay time starts (as per the mode selected)
3. Delay time concluded, float switch in close position, pump starts.
4. Delay time concluded, float switch open, pump won't start. Cycle begins again once float switch closes.

Standard Mode: In this mode the controller will run the pump at all times, unless the float switch is in the open position or the timer mode has been selected.

Timer Mode: When the timer button is pressed on the controller, the pump will run for the selected time as per the dip switch setup. Once the selected time is completed the pump will stop and the controller will need to be reset (by switching the controller off and on) before it resumes normal operation.

Operation

Subrotor Controller Indicator Lights and Their Meaning

LED	Description
	Off
	On
	Flashing
Controller Display	Left LED, Right LED : Sub Rotor System State
	Off, Off : The pump is off and there is no power.
	On, Off : The pump is running.
	On, Flashing : The pump is running, count down timer is engaged. Pump will stop once count down has been finalised.
	Off, Flashing : The pump is off after count down time has been completed.
	Flashing, On: The pump is off but will start once float delay has been completed.
	Flashing, Off : The pump off due to over voltage or under voltage has occurred. Unit will operate once voltage has been corrected.
	Off, On : The pump is off because the float switch is open. The pump will operate once flat switch closes. Note that there may be a delay from when the switches closes to when the pump begins.
	Flashing, Flashing : Unknown state (switch unit off). Possible hardware fault, send back to Mono Pumps.

Operation

Examples of use:

I just want to pump water.

Install unit. And Switch on. There will be no need for setting dip switches.

I want to use the timer

Install unit. Set dip switch to one of the standard modes (10-150 mins). Switch unit on. Press timer button and unit will run for the time selected. Once timed out the pump will stop and not run again until button is pressed.

I want to use the float switch or bore probe with no start delay

Install unit. Set dip switch to one of the standard modes (10-150 mins). Switch unit on. When the float switch opens the pump will stop when the float switch closes the pump will start (no delay).

I want to use the float switch bore probe but with a delay

Install unit. Set dip switch to one of the float modes (10-150 mins). Switch unit on. When the float switch opens the pump will stop when the float switch closes there will be a delay before the pump will start. This delay will be as selected (10-150 mins). The main purpose of having a delay is to let a bore refill after drawing the water level down.

I am using a pressure switch, what mode do I use

If the pressure switch is switching the power only to the controller then it does not matter. The pump will start as soon as power is applied. If the pressure switch is wired in to the float switch termination, then use one of the standard modes (10-150mins). The pump will start as soon as the pressure switch closes due to a drop in pressure.

Maintenance

Subrotor Pump Wet End - Disassembly

1. Remove the four nuts and spring washers connecting the pump to the motor.

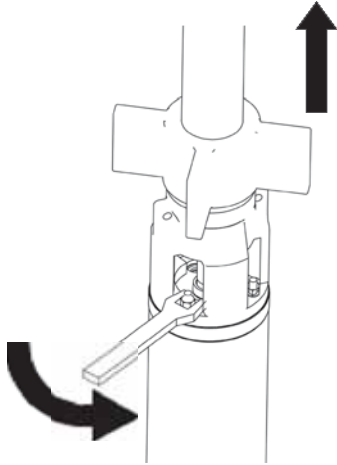

2. Pull the pump off the rotating assembly. Be careful to pull in a straight line to prevent damage to the flexishaft coating.

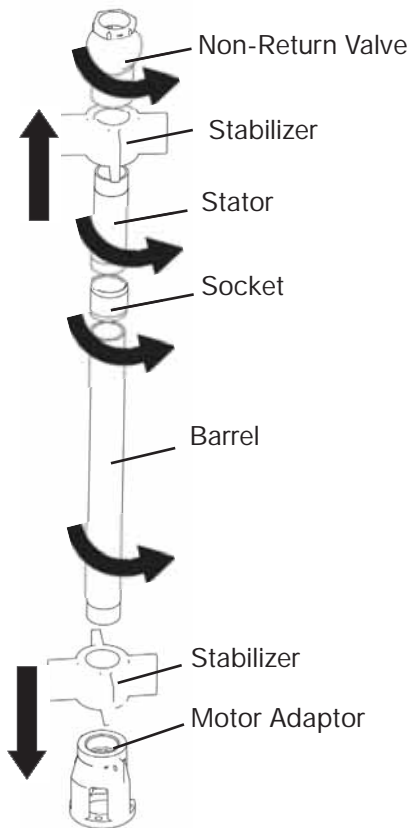

3. To remove the stator grip the non-return valve in a vice or pipe wrench and unscrew the stator by gripping the socket with a second wrench.



When removing the stator it is very important that the tube is not distorted by pipe wrenches, vice jaws etc. Damage to the outside of the stator tube can result in loss of performance and seizure of the pump.

4. Inspect the stator for signs of damage to the rubber surface and replace if necessary. It is generally not necessary to disassemble the pump barrel from the motor adaptor.



5. Do not damage the green Halar coating on the flexishaft. Attempting to remove the flexishaft by gripping it with a pipe wrench will destroy the coating and void the warranty. The Halar coating protects the flexishaft from corrosion. Damage to the coating can lead to failure of the flexishaft.

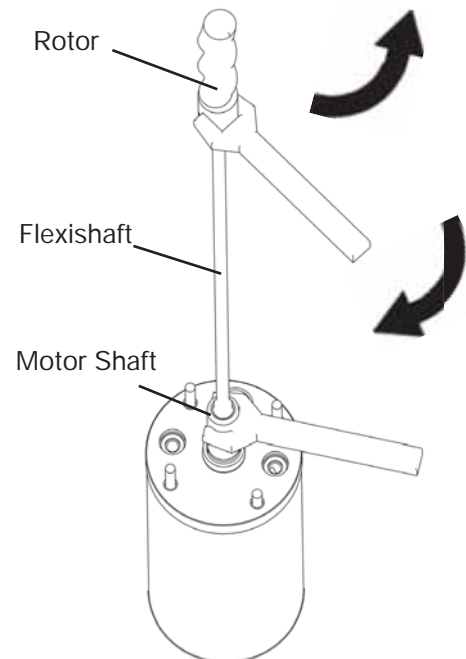

Maintenance

To remove the rotor from the flexishaft, unscrew the rotor by using a spanner on the flat on the rotor and a second spanner on the flats on the motor shaft. Do not grip the flexishaft. If the flexishaft unscrews from the flexishaft adaptor and remains in the rotor it will be necessary to carefully grip the exposed metal between the thread and the green Halar coating with multigrips (or similar) and unscrew the rotor using a spanner on the flats. Ensure that soft jaws or similar are used to prevent damage to the flexishaft.

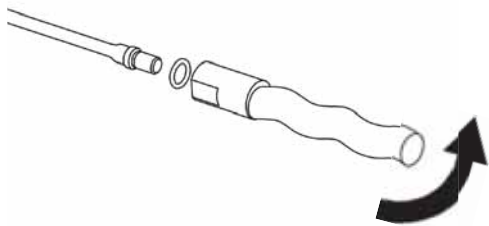

6. Inspect the rotor for signs of wear and replace if damaged. If it is necessary to replace the rotor it is recommended that the stator be replaced at the same time.

Subrotor Pump Wet End - Assembly



There is a risk that the stainless steel threads on the flexishaft adaptor and the motor coupling may pick-up and seize during this procedure. If this occurs both components may be damaged beyond repair and it will be very difficult to remove them from the motor.

1. Always replace the o-rings in the motor coupling and rotor with new parts. Coat the flexishaft threads with nickel or copper based anti-seize. Screw the assembly together by hand. Tighten using a spanner on the rotor head flat and a second spanner on the motor coupling.

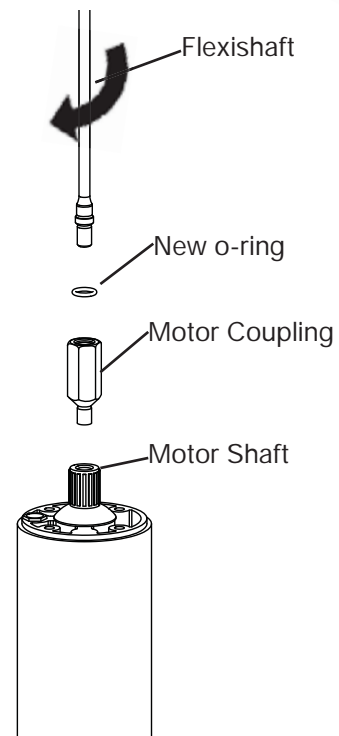
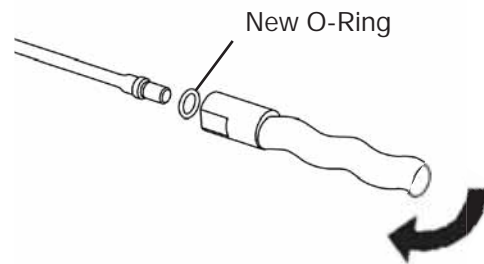

Maintenance

2. If the pump barrel has been removed from the motor adaptor piece, reassemble these components first. Fit a stabiliser over the pump barrel. Lightly coat both pump barrel threads with Stag pipe sealant. If too much Stag is used, the excess could be washed into the stator causing damage to the stator and seizure of the pump. Screw the pump barrel into the motor adaptor piece by hand. Screw the socket onto the pump barrel.

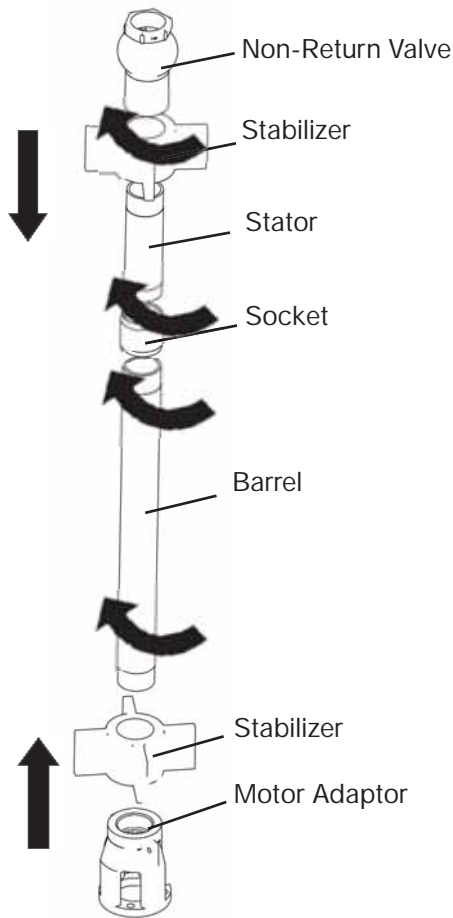

3. Check the orientation of the stator - one end is marked "Suction This End". Fit a stabiliser over the stator. Lightly coat both stator threads with Stag pipe sealant - be careful not to use excessive amounts. Screw the suction end of the stator into the socket by hand.
4. Screw the non-return valve onto the stator. (Make sure the check valve is on the correct way such that the flow through the pump will open the valve).



5. Do not tighten the stator connections by using a pipe wrench, vice etc. on the stator tube. It is very important that the stator is not distorted by pipe wrenches, vice jaws etc. Damage to the outside of the stator tube can result in loss of performance and seizure of the pump.

Tighten the assembly using a spanner or pipe wrench on the check valve and by passing a rod or large screwdriver through the motor adaptor piece. It is important that this assembly is tight to prevent it unscrewing in service. The Stag pipe sealant will act as a thread-locking agent when dry.



6. Do not use grease, soap, hand cream, etc. to lubricate the Stator. These products will damage the natural rubber stator and result in seizure of the pump. When assembling the rotor into the stator it is only necessary to wet the components in water.

Wet the rotor and stator with water and slide the stator assembly over the rotor assembly. Some resistance will be felt as the rotor is pushed into the stator. Align the motor adaptor piece with the cable outlet on the motor and the motor studs. Push the stator assembly home. Fit the four spring washers over the studs. Fit the four M8 nuts and tighten with a spanner.

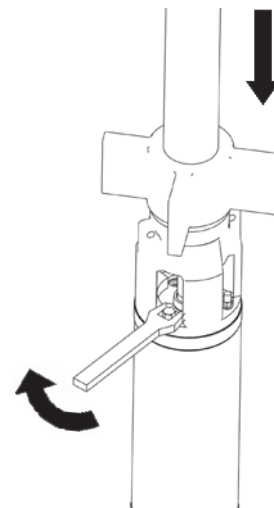

Spare Parts

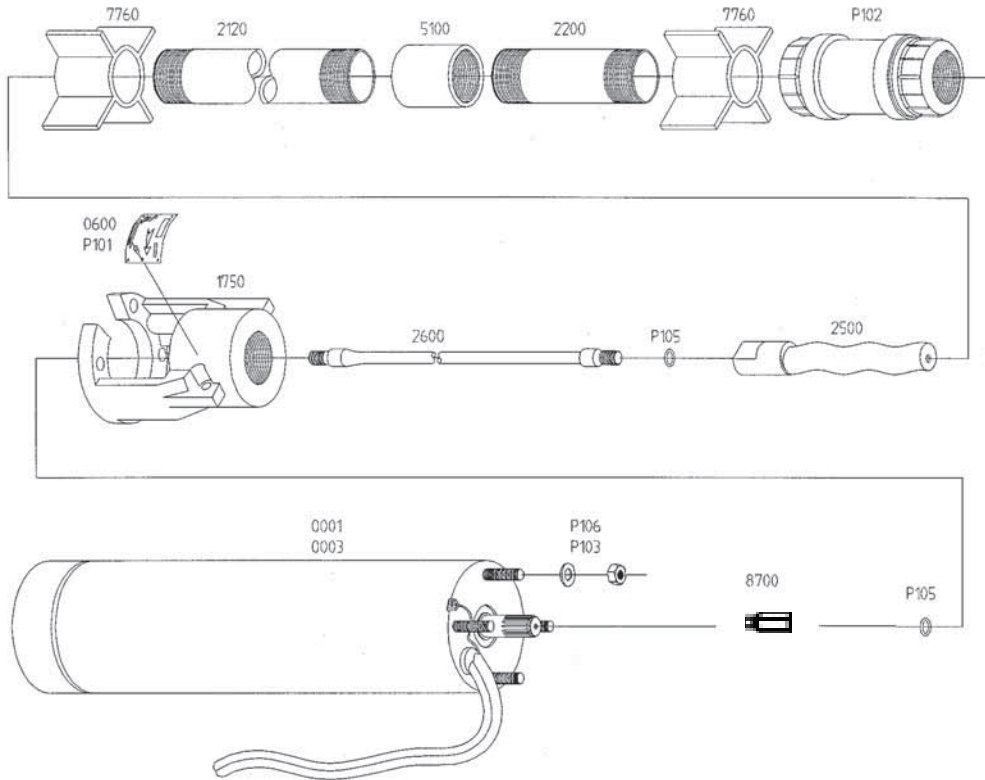

ITEM	COMMON PARTS	QTY	PART NUMBER	ITEM	COMMON PARTS	QTY	PART NUMBER
0001	MOTOR 240V 1 PHASE	1	SEE CHART BELOW	5100	SOCKET	1	SF SM041 5130
0003	MOTOR 415V 3 PHASE	1	SEE CHART BELOW	7760	STABILIZER	2	RB STA 155x040
0600	NAMEPLATE	1	SF SM022 0610	8700	MOTOR COUPLING	1	SUN M0812
1750	MOTOR ADAPTOR PIECE	1	ST SM041 1750	P101	DRIVESCREW	2	R104100F
2120	PUMP BARREL	1	SS SM041 2120	P102	VERTICAL CHECK VALVE	1	VCV150
2200	STATOR	1	SEE CHART BELOW	P103	SPRING WASHER	4	SUN 23185-3
2500	ROTOR	1	SEE CHART BELOW	P105	O RING	2	S211120P
2600	FLEXISHAFT COATED	1	SM SM151 2650	P106	HEX NUT	4	SUN 23184-3
					OMNIFIT 1790 (10ML)	1	SWP-15103

PUMP MODEL	0001-1 PHASE MOTOR	0003-3 PHASE MOTOR	2500 - ROTOR	2200 - STATOR
SM0222	ESM 101	ESM 103	SF SM022 2530	RA SM022 2210
SM0412	ESM 101	ESM 103	SF SM041 2530	RA SM041 2210
SM0422	ESM 201	ESM 203	SF SM042 2530	RA SM042 2210
SM0612	ESM 151	ESM 153	SF SM061 2530	RA SM061 2210
SM0622	ESM 301	ESM 303	SF SM062 2530	RA SM062 2210
SM1012	ESM 201	ESM 203	SF SM101 2530	RA SM101 2210
SM1022	ESM 301	ESM 301	SF SM102 2530	RA SM102 2210
SM1512	ESM 301	ESM 301	SF SM151 2530	RA SM151 2210

Fault Finding

SYMPTOM	CAUSE OF TROUBLE	CHECKING PROCEDURE	CORRECTIVE ACTION	
Pump does not start.	No power or incorrect voltage.	Voltage must be +/- 5% rated voltage.	Contact supply authority for correction and voltage symmetry.	
	Fuses blown or circuit breaker tripped.	Check fuses. Check for tripped circuit breaker.	Replace with proper fuse or reset circuit breaker.	
	Defective pressure switch.	Check voltage at contact points.	Replace pressure switch or clean points.	
	Control box malfunction.	The magnetic coil in the motor starter/contactor is short-circuited. (Not cutting in). The contacts in the motor starter/ contactor are defective. The control circuit has cut out or is defective. The start/run capacitors are defective.		Replace the coil. Check the coil (3 phase units).
				Replace the contacts.
				Check the control circuit.
				Replace capacitor/s. (1 phase unit).
	Pump full of sand.	Solids within hydraulic elements through damaged or misplaced screens.	Remove and clean pump.	
	Water temperature exceeds 30°C.		Contact Mono Pumps.	
	Defective wiring.	Check for loose or corroded connections.	Correct faulty wiring or connections.	
Float switch is open.	Check status lights.	Repair or replace float switch.		
Pump has tried to start too many times, Cooling down timer activated.	Check status lights.	Check installation of system. Pull out, replace or repair pump.		
System has completed timing mode.	Check status lights.	Reset the system by turning the controller off and on.		
Starting is difficult.	A phase to motor is missing (3 phase) or there is an interruption in winding.	Using an ohmmeter check continuity.	Check contact points, fuses and connections to control box terminals.	
Pump starts too often.	Pressure switch.	Check pressure switch setting and examine for defects.	Reset limit or replace switch.	
	Damaged non-return valve.	Ascertain if pressure decreases without water delivery.	Pull out the pump and replace or repair the valve.	
	Air leaks from water tank.	Check air volume and relief valve for proper seal.	Drain, clean and recharge tank with proper air cushion.	
	Pressure tank/diaphragm tank is too small.	Consult Mono dealer.	Replace with larger tank, or fit additional tank.	
	Leak in system.	Check system for leaks.	Check and repair the pipework. Pull out the pump, repair or replace the riser pipe.	
	Pressure tank pre-charge low.	Switch off unit, open outlet valve and drain system before checking pre-charge pressure at air valve.	Re-charge to 2.3 psi (15 kpa) below cut-in pressure. If tank does not charge, replace diaphragm.	
Pump runs continuously.	Pressure switch.	May be too high or contact points welded in closed position.	Clean contact points and reset limit.	
	Water level too low in well.	Pump may exceed well capacity or not be submerged.	Lower pump suction to 1 m at least. Do not lower to levels where sand and debris deposits are heavy.	
	Worn hydraulic elements.	Check head in the closing stage and flowrate.	If flowrate is less than rated, repair or replace pump.	
	Worn pump.	Symptoms of worn pump are similar to those of drop pipe leak or low water level in well. Reduce pressure switch setting. If pump shuts off, worn parts may be at fault.	Pull pump and replace worn stator and/or rotor.	
	Pump screen clogged with deposits.	Flowrate measurement will read considerably lower than rated.	Clean screen and, if required, drain and clean the well.	
	Non-return valve stuck closed.		Replace defective valve.	
	Open tap or leaking pipe in system.	Isolate system as close as possible to pressure tank and check if pump switches off.	Check system for leaks and repair.	
The pump runs but produces no water.	No water or water level is too low in borehole.	Check the water level during operation.	Lower the pump to give at least 1m of water above inlet. Do not lower to level where sand or debris can be drawn in.	
	The non-return valve is blocked in its shut position.	Pull out pump and check the valve.	Replace the check valve.	
	The pump is defective.	Pull out pump and check the pump.	Repair or replace worn parts.	

Fault Finding

SYMPTOM	CAUSE OF TROUBLE	CHECKING PROCEDURE	CORRECTIVE ACTION
The pump runs at reduced capacity.	The pump has been incorrectly selected.	Measure the discharge head and compare with the calculated data.	Replace the pump by one with a larger discharge head.
	The draw down is larger than anticipated.	Check the draw down during operation and compare with the pump, borehole and pump data.	Increase the installation depth. Replace it with a smaller model to obtain a smaller capacity.
	The valves in the discharge pipe are partly shut/ blocked.	Disconnect discharge pipe at bore head and check flow.	Overhaul the valves.
	The discharge pipe is partly choked by impurities.	Pull out pump.	Clean or replace riser pipe.
	The non-return valve of the pump is partly blocked.	Pull out pump.	Replace or repair the non-return valve.
	The pump is defective.	Pull out pump.	Pull out, replace or repair pump.
Air or milky water from taps.	The discharge (riser) pipe is leaking.	Pull out pump.	Check riser pump and joints for corrosion and leaks. Replace riser pipe, remake joints.
	Defective air volume control (conventional pressure tank only).	Check water air ratio in tank. Check air volume control.	Replace air volume control.
	Air being pumped with water.	Check for air at borehead at reduced flow. Gaseous well water.	Lower pump to give at least 1m of water above inlet. Do not lower to level where sand or debris can be drawn in. Fit shroud (for gaseous water) to
No lights on subrotor controller.	No power.	Check main switchboard.	Contact supply authority for correction.
	Breaker switch off.	Check to see if the breaker switch is in the "off" position.	Switch the breaker switch back into the "on" position. If the breaker has been tripped too many times, this indicates that there may be a problem with the pump. Pull pump and replace or repair.
	Faulty.		Contact Mono Pumps.

UK and Europe

Mono Pumps Ltd, Martin Street, Audenshaw
Manchester, M34 5JA, England
T. +44 (0)161 339 9000
E. info@mono-pumps.com

Americas

NOV Monoflo, 9606 Kirkton
Houston, Texas 770495, USA
T. +1 281 200 1200
E. inquire@monoflo.com

Monoflo SA

Ing. Huergo 2239 - B1842GGW
Monte Grande
Buenos Aires
Argentina
T. +54 4296 8997
F. +54 4284 0323
E. inquire@monoflo.com

Australasia

Mono Pumps (Australia) Pty Ltd
Mono House, 338-348 Lower Dandenong Road
Mordialloc, Victoria 3195, Australia
T. +61 (0)3 9580 5211
E. ozsales@mono-pumps.com

Mono Pumps (New Zealand) Ltd
PO Box 71-021, Fremlin Place, Avondale
Auckland 7, New Zealand
T. +64 (0)9 829 0333
E. info@mono-pumps.co.nz

Asia

Mono Pumps Ltd, No. 500 YaGang Road
Lujia Village, Malu, Jiading District
Shanghai 201801, P.R. China
T. +86 (0)21 5915 7168
E. monoshanghai@nov.com

www.mono-pumps.com



One Company, Unlimited Solutions